

REVISED STARTING
SERIAL #070310257

PARTS LIST MANUAL

8" WALK BEHIND SCARIFIER



**MODEL
CPM8-9H
SHOWN**

CPM8 SCARIFIERS

SKU #	MODEL #	POWER OPTION
79300	CPM8-9H	HONDA 9 HP GX270 GASOLINE ENGINE W/CYCLONE AIR CLEANER
70300	CPM8-9S	SUBARU ROBIN 9 HP EX 27 GASOLINE ENGINE W/CYCLONE AIR CLEANER
79500	CPM8-5B/230/1	BALDOR 5 HP ELECTRIC MOTOR, 60 Hz, 1 PHASE, 230 VOLT, 19.5 F.L. AMPS
79400-230	CPM8-5B/230/3	BALDOR 5 HP ELECTRIC MOTOR, 60 Hz, 3 PHASE, 230 VOLT, 12 F.L. AMPS
79400-460	CPM8-5B/460/3	BALDOR 5 HP ELECTRIC MOTOR, 60 Hz, 3 PHASE, 460 VOLT, 6 F.L. AMPS
79400-50/220	CPM8-5B/50/220/3	BALDOR 5 HP ELECTRIC MOTOR, 50 Hz, 3 PHASE, 220 VOLT, 13 F.L. AMPS
79400-50/380	CPM8-5B/50/380/3	BALDOR 5 HP ELECTRIC MOTOR, 50 Hz, 3 PHASE, 380 VOLT, 7.6 F.L. AMPS
79400-50/440	CPM8-5B/50/440/3	BALDOR 5 HP ELECTRIC MOTOR, 50 Hz, 3 PHASE, 440 VOLT, 6.5 F.L. AMPS



A Division of Equipment Development Company, Inc.

100 Thomas Johnson Drive, Frederick, MD 21702-4600 USA
Phone (301) 663-1600 • 1-800-638-3326
Fax (301) 663-1607 • 1-800-447-3326
Website: www.edcoinc.com
Email: sales@edcoinc.com

Printed in USA

©2007

READ AND UNDERSTAND THE OPERATORS INSTRUCTION MANUAL THOROUGHLY BEFORE ATTEMPTING TO OPERATE THIS EQUIPMENT. Death or serious injury could occur if this machine is used improperly.



SAFETY MESSAGES



The safety instructions are preceded by a graphic alert message of DANGER, WARNING, or CAUTION.



Indicates an imminent hazard which, if not avoided, will result in death or serious injury.



Indicates an imminent hazard which, if not avoided, can result in death or serious injury.



Indicates hazards which, if not avoided, could result in serious injury and or damage to the equipment.

GASOLINE Powered Equipment



- Do not operate gasoline powered equipment without adequate ventilation. Carbon monoxide is an invisible, odorless gas that can kill.

ELECTRICAL Powered Equipment



- ELECTRICAL HAZARD** - Be sure equipment is properly grounded. Failure to comply could kill or result in serious injury.



The engine exhaust from this product contains chemicals known to the State of California to cause cancer, birth defects or other reproductive harm.

GENERAL INSTRUCTIONS



- You must read and understand the operators instruction manual and all other manuals associated with this machine. For your safety and the safety of others around you, it is extremely important to fully understand how to operate this machine in the way it was intended. Different model machines or older/newer versions of the same model may have different parts and controls that you need to understand. If instructions are not readable or available DO NOT USE this machine and contact the factory for a replacement Manual.
- You must be able to physically handle the bulk weight and power of this machine. If not properly controlled this machine can cause death or serious injury.
- Do not operate this machine in an impaired mental state. You must be able to exercise good judgement and reactions to maintain a safe working environment.
- This is a "one person" machine which means only one operator can be operating the machine at any one time. For the safety of others, maintain a safe operating distance to other personnel. Your work area should be defined and appropriately marked so bystanders and coworkers do not stand or walk near this machine and end up seriously injured by flying debris or exposing them to harmful noise or dust.
- This equipment is for Commercial use. Although this is a "one person" machine your work team should understand how to shut this machine off and quickly get medical help if an accident strikes the operator.
- Keep all guards in place during operation. The guards are to provide protection from inadvertent contact with dangerous moving parts, pinch points, or hot surfaces.
- Wear appropriate Personal Protective Equipment (PPE) including safety glasses, safety boots, work gloves, respiratory protection, hearing protection, and head protection. Do not wear loose clothing that can get tangled in moving parts. Failure to do so could result

in dismemberment or death. **Wear an approved respirator when removing hazardous materials or when grinding/cutting dry materials. Some dust particles such as concrete dust can contain silicate particles which can cause silicosis (a very serious lung disease). Contact NIOSH or OSHA for further details. When wet grinding/cutting, avoid contact with the concrete/asphalt slurry which can cause serious skin irritations.**

- You must maintain this machine per the maintenance schedule in the operator manual. Remember before adjusting, servicing, or fueling this machine, disconnect the source of power to the machine by disconnecting the spark plug (Gas models), or by unplugging the electrical power cord (electric models) or air hose (Pneumatic models) AT THE MACHINE so you can assure yourself it remains unplugged while you are working on it. Do not modify this machine. Use only genuine EDCO parts and accessories. Repairs and service should be performed by approved EDCO dealers or authorized technicians.
- You should look carefully around the area before you begin work so you can identify potential hazards such as deck inserts, pipes, columns, openings, electrical cords or outlets, or any other objects protruding from the slab surface.
- This machine has no brain so you must use your own. There is no substitute for safety. The safety decals on the machine are to serve as a reminder for information you must already know before you begin using this machine. Take a moment to reread the safety decals each time you use the machine. If your machine is missing any decals, contact the factory for a replacement (EDCO 1-800-638-3326).

PARTS LIST MANUAL

MODEL CPM8

<u>Section</u>	<u>Page Number</u>
Safety Messages / General Instructions.	2
How To Order Replacement Parts.	3
Illustration 1 : Frame Grouping	4,5
Illustration 2 : Drum Shaft & Bearing Grouping	6
Illustration 3 : Engine & Belt Drive Grouping	7
Illustration 4 : Motor & Belt Drive Grouping	8,9
Illustration 5 : Cutter Drum Assembly	10
Illustration 6 : Diamond Grooving Head Assembly	11
Illustration 7 : Optional Edger Assembly	12
Illustration 8 : Edger Cutter Drum Assembly	13
Illustration 9 : Optional Shaft Cover Kit	14
Wiring Diagram For Electric Units	15
Limited Equipment Warranty of Sale.	Back Page

<p style="text-align: center;">HOW TO ORDER REPLACEMENT PARTS</p> <ul style="list-style-type: none"> <input type="checkbox"/> To insure product safety and reliability, always use genuine EDCO replacement parts when making repairs to the equipment. <input type="checkbox"/> When calling for parts, specify the MODEL and SERIAL number of the machine, which can be found on the NAME PLATE. Keep that information in the space provided. In addition to this information, give part number, description, and quantity as listed on the parts list to your parts representative. <input type="checkbox"/> Please note: Due to improvements and changes in the equipment, the illustrations shown may be different than the actual machine. 	<p style="text-align: center;">FILL IN INFORMATION BELOW</p> <p>Date of Purchase _____</p> <p>Model # _____</p> <p>Serial # _____</p> <p>SKU # _____</p>
------------------------------------------------------------------------------------------------------------------------------------------------------------------------------------------------------------------------------------------------------------------------------------------------------------------------------------------------------------------------------------------------------------------------------------------------------------------------------------------------------------------------------------------------------------------------------------------------------------------------------------------------------------------------------------------------------------------------------------------------------------------------------------------	-----------------------------------------------------------------------------------------------------------------------------------------------------------------



100 Thomas Johnson Drive, Frederick, MD 21702-4600 USA
 Phone (301) 663-1600 • 1-800-638-3326
 Fax (301) 663-1607 • 1-800-447-3326
 Website: www.edcoinc.com
 Email: sales@edcoinc.com

PARTS LISTING - ILLUSTRATION 1: FRAME GROUPING

ITEM#	PART#	DESCRIPTION	QTY.	ITEM#	PART#	DESCRIPTION	QTY.
1	65009	HANDLE BAR	1	43	52001	WHEEL 4 X 1-1/2 X 3/4"BRG.	2
2	10608	GRIP, HAND 1' MODEL AT	2	44	65002	MOUNT, ENGINE/MOTOR	1
3	14023	KNOB, BALL 1-3/8"DIA w/ 1/2-13 THD.	2	45	10021	SCREW, CAP 3/8-24 x 1	2
4	10127	SCREW, DRIVE 1/8 x 1/4 L	1	46	10025	WASHER, FLAT 3/8	4
5	10808	FITTING, GREASE 1/4-28 STRAIGHT	2	47	10004	NUT, LOCK 3/8-24	2
6	65019	HANDWHEEL, SMALL W/ 5/8-8 X 13"ROD	1	48	10802	BOLT, CARRIAGE 3/8-16 x 1	2
7	10411	SCREW, SKT. HD. CAP 1/2-13 X 4 ZINC	1	49	10025	WASHER, FLAT 3/8	4
8	50550	SLEEVE FOR 1/2" CAPSCREW, TAPERED	1	50	10811	WASHER, LOCK 3/8	4
9	85005	BEARING, THRUST BALL 5/8	1	51	10404	NUT 3/8-16	2
10	10073	WASHER, FLAT 5/8 SAE	1	52	65001	MAIN FRAME	1
11	65007	LINKAGE SUPPORT, UPPER	1	53	10909	BOLT, CARRIAGE 3/8-16 X 3 FULL THD.	1
12	10359	SCREW, CAP 5/8-11 x 3-1/4	1	54	10404	NUT 3/8-16	1
13	10073	WASHER, FLAT 5/8	3	55	65017	SCREW, CAP 1/2-20 X 5	2
14	79035	BUSHING, RUBBER 1-1/16 OD 5/8 ID x 1/4 THK	1	56	65016	SPACER TUBE 1/2"ID X 3-9/16"L	2
15	10096	COLLAR, LOCKING 5/8"ID	1	57	10072	NUT 1/2-20	2
16	65021	CAP, END 2" RED PLASTIC	1	58	10312	WASHER, FLAT 1/2 SAE	4
17	86347	BRACKET, MULTI-VAC PORT 2-3"	1	59	65003	COVER, BELT	1
18	10038	WASHER, LOCK 1/4	2	60	10045	WASHER, LOCK 1/2	2
19	10846	SCREW, CAP STSHW 1/4-20 X 1/2	2	61	10422	NUT, ACORN 1/2-20	2
20	10766	CLAMP, HOSE, SAE #28, ADJ. TO 2-1/4	2	62	65022	PLUG, HOLE 2"	1
21	65098	HOSE, FLEX 2"ID X 22"L	1	63	65036	BRUSHES (SET OF 4)	1
22	56022	BRACKET, WATER VALVE	1	64	10834	SCREW, CAP 1/4-20 X 1/2	8
23	10846	SCREW, CAP STSHW 1/4-20 X 1/2	2	65	10861	NUT, KEPS 1/4-20	8
24	10038	WASHER, LOCK 1/4	2	66	10304	SCREW, CAP 1/2-20 X 1	2
25	65089	HOSE, WATER 3/8"ID X 19-1/4"L	1	67	10045	WASHER, LOCK 1/2	2
26	50069	CLAMP, HOSE, SAE #6, ADJ. TO 13/16	2	68	65014	AXLE SHAFT 3/4"DIA. X 12-7/32"L	1
27	11562	BARB ELBOW 90, 3/8 HOSE X 1/8 MPT	2	69	10428	COLLAR, LOCKING 3/4"ID	2
27A	10864	NUT 1/8-27 PIPE THREAD	1	70	52001	WHEEL 4 X 1-1/2 X 3/4"BRG.	2
28	10711	VALVE, BALL 1/2 FPT	1				
29	80021	CONN., SWIVEL FEM. 3/4HOSE X 1/2MPT (INCLUDES ITEM 30)	1				
30	10070	WASHER, HOSE 3/4	1				
31	10055	SCREW, CAP 3/8-16 X 1	4				
32	10811	WASHER, LOCK 3/8	4				
33	10025	WASHER, FLAT 3/8 SAE	4				
34	65006	LINKAGE, LOWER	1				
35	81001	SCREW, CAP 1/2-13 X 4	1				
36	10407	NUT, LOCK 1/2-13	1				
37	65015	SCREW, CAP 1/2-13 X 8	1				
38	10312	WASHER, FLAT 1/2 SAE	2				
39	10407	NUT, LOCK 1/2-13	1				
40	65004	FORK	1				
41	10306	PIN, COTTER 3/16 X 1-1/4	2				
42	65005	SPACER, REAR WHEEL, 2-1/8"	2				



A Division of Equipment Development Company, Inc.

100 Thomas Johnson Drive, Frederick, MD 21702-4600 USA
 Phone (301) 663-1600 • 1-800-638-3326
 Fax (301) 663-1607 • 1-800-447-3326
 Website: www.edcoinc.com
 Email: sales@edcoinc.com

Printed in USA

©2007

Page 5

ILLUSTRATION 2: DRUM SHAFT & BEARING GROUPING

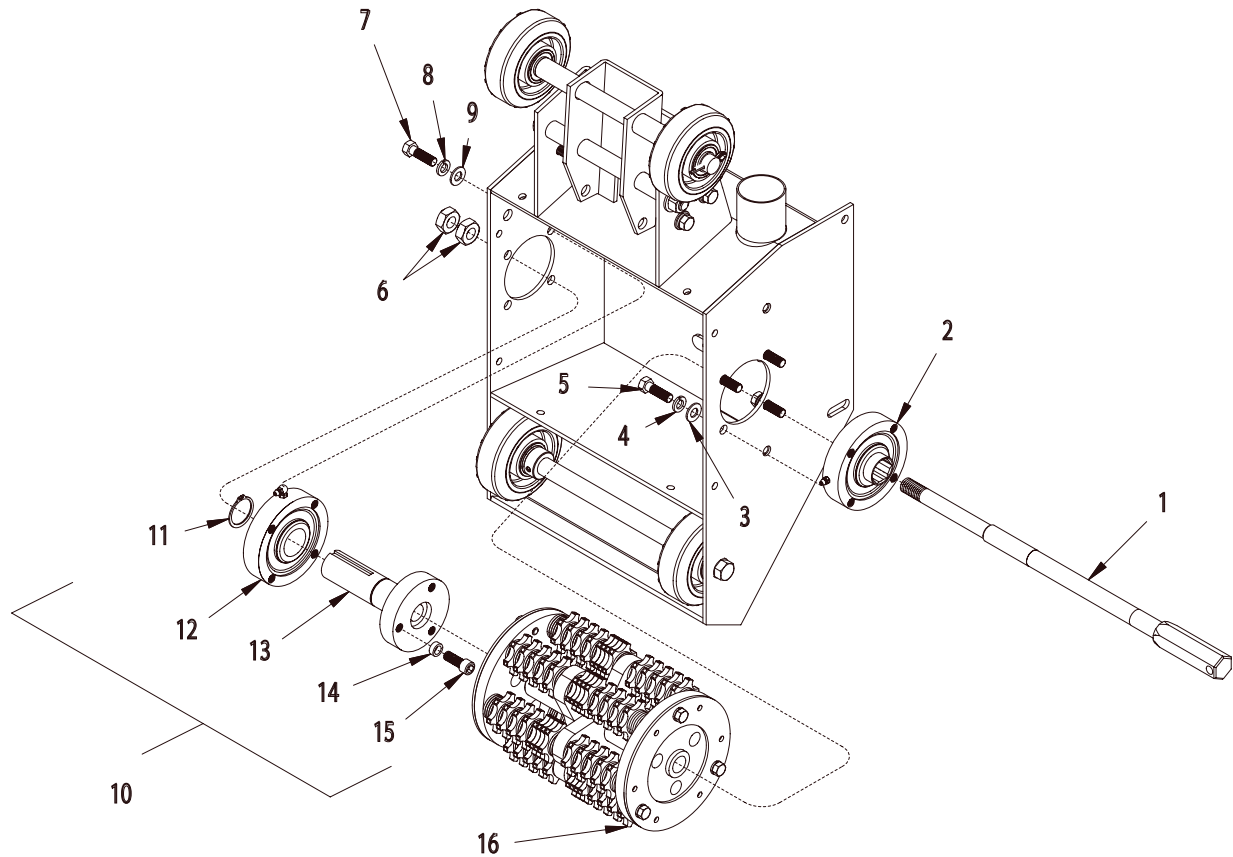

ITEM#	PART#	DESCRIPTION	QTY.
1	65037	DRUM SHAFT 18-3/8"	1
2	65057	BEARING ASSY. COMPLETE, 1"HEX BORE	1
3	10025	WASHER, FLAT 3/8 SAE	4
4	10811	WASHER, LOCK 3/8	4
5	10309	SCREW, CAP 3/8-24 X 1-1/4 PLATED	4
6	65039	NUT, JAM 5/8-11 LEFT-HAND THREAD	2
7	10309	SCREW, CAP 3/8-24 X 1-1/4 PLATED	4
8	10811	WASHER, LOCK 3/8	4
9	10025	WASHER, FLAT 3/8 SAE	4
10	65038A	DRIVER W/ BEARING ASSY (ITEMS 11 THRU 15)	1
11	10873	RETAINING RING, EXT. 1-1/4"	1
12	65056	BEARING ASSY. COMPLETE, 1-1/4"DIA.	1
13	65038	DRIVER	1
14	10113	SPACER, STEEL 9/16OD X 3/8ID X 7/32	3
15	10878	SCREW, SKT. HD. CAP 3/8-24 X 1	3
16	-----	CUTTER DRUM ASSEMBLY (REFER TO ILLUS. 5 FOR BREAKDOWN)	

ILLUSTRATION 3: ENGINE & BELT DRIVE GROUPING

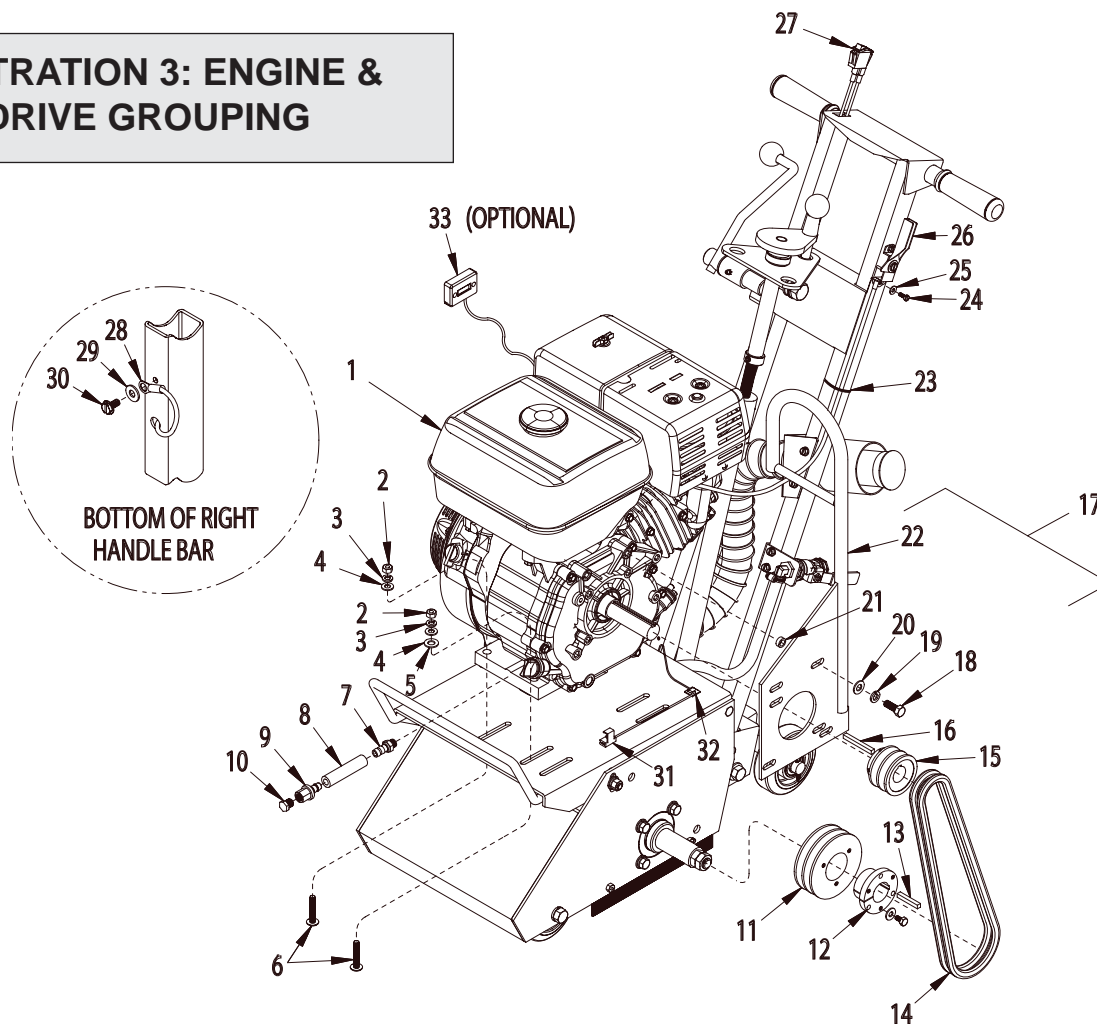

ITEM#	PART#	DESCRIPTION	QTY.	ITEM#	PART#	DESCRIPTION	QTY.
1		ENGINE	1	15	10553	SHEAVE 2.5"OD X 2GR.A X 1"BORE	1
	15027	HONDA 9.0 HP GX270-QXC9 w/ CYCLONE AIR CLEANER		16	10307	KEY 1/4SQ X 2-1/4	1
	15063	ENGINE, SUBARU ROBIN 9 HP EX27 CYC.		17	30101A	LIFTING BAIL KIT (INCLUDES ITEMS 18-22), (OPTIONAL)	1
2	10054	NUT 5/16-18	4	18	10055	SCREW, CAP 3/8-16 X 1	4
3	10801	WASHER, LOCK 5/16	4	19	10811	WASHER, LOCK 3/8	4
4	10213	WASHER, FLAT 5/16	4	20	10025	WASHER, FLAT 3/8 SAE	4
5	10025	WASHER, FLAT 3/8	2	21	10113	SPACER, STEEL 9/16OD X 3/8ID X 7/32	4
6	10918	BOLT, CARRIAGE 5/16-18 x 1-3/4	4	22	30101	LIFTING BAIL, HORZ. SHAFT	1
7	11542	BARB, PUSH-ON 3/8HOSE X 12MM X 1.50 (HONDA ONLY)	1	23	10982	TIE, CABLE, BLACK NYLON 11-1/4"	1
	10657	BARB, PUSH-ON 3/8HOSE X 1/4MPT (SUBARU ROBIN ONLY)	1	24	10877	SCREW, CAP STSHW 10-24 X 1/2	2
8	56116	HOSE, PUSH-ON 3/8"ID X 3"L	1	25	10831	WASHER, LOCK, INT. TOOTH #10	2
9	11544	BARB, PUSH-ON 3/8 HOSE X 1/4FPT	1	26	40388	CABLE, THROTTLE, LEVER-TYPE 24"	1
10	10776	PIPE PLUG 1/4 NPT (BRASS)	1	27	15201A	SWITCH W/ WIRES, ROCKER RED ON-OFF	1
11	65045	SHEAVE 4.05"OD X 2GR.A X SH	1	28	50084	TERM., RING #10 16-14GA. INSULATED	1
12	10505	BUSHING, SHEAVE SH X 1-1/4"BORE	1	29	10831	WASHER, LOCK, INT. TOOTH #10	1
13	40317	KEY 1/4SQ X 1-5/8	1	30	10877	SCREW, CAP STSHW 10-24 X 1/2	1
14	81007	BELT AX-33	2	31	10970	CONN., WIRE QUICK-SPLICE 18-14 GA.	1
				32	36042	CLIP, NATURAL CORD, 1/8" X 1/4"	1
				33	15138	METER, HOUR, INDUCTIVE (OPTIONAL)	1



100 Thomas Johnson Drive, Frederick, MD 21702-4600 USA
 Phone (301) 663-1600 • 1-800-638-3326
 Fax (301) 663-1607 • 1-800-447-3326
 Website: www.edcoinc.com
 Email: sales@edcoinc.com

Printed in USA
 ©2007
Page 7

ILLUSTRATION 4: MOTOR & BELT DRIVE GROUPING

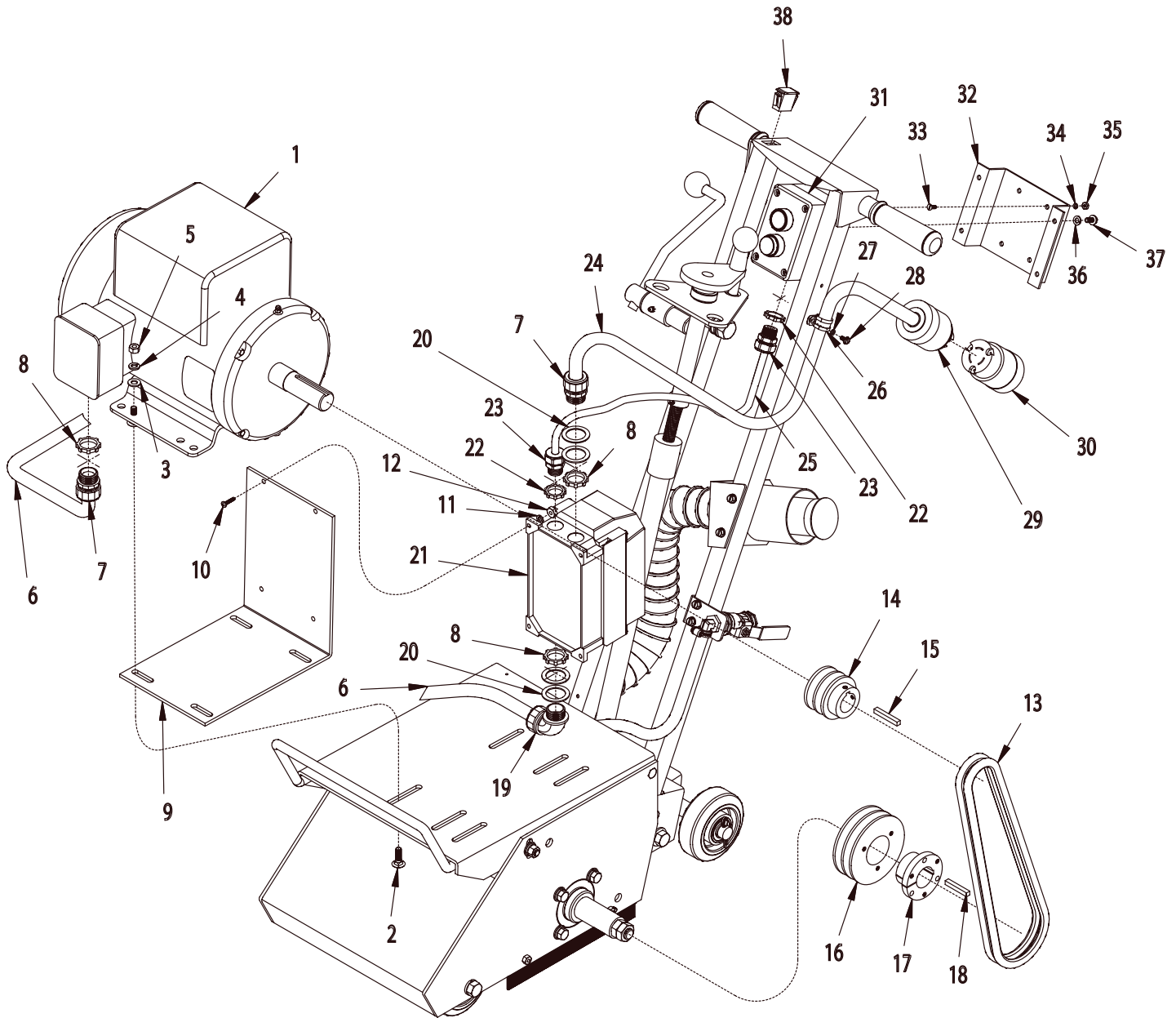

PARTS LISTING - ILLUSTRATION 4: MOTOR & BELT DRIVE GROUPING

ITEM#	PART#	DESCRIPTION	QTY.
1		MOTOR (REQUIRES HOLES DRILLED IN BASE FRAME)	1
	81026	BALDOR 5.0HP - 1PH, 60Hz, 3450 RPM, 230V	
	81022	BALDOR 5.0HP - 3PH, 60 Hz, 3450 RPM, 230/460V	
	16020	BALDOR 5.0HP - 3PH, 50 Hz, 2850 RPM, 220/380/440V	
2	10819	BOLT, CARRIAGE 5/16-18 x 1	4
3	10213	WASHER, FLAT 5/16-18	4
4	10801	WASHER, LOCK 5/16-18	4
5	10054	NUT 5/16-18	4
6		WIRE HARNESS, STARTER TO MOTOR	1
	65107	10/3 x 28" LOA (1 PHASE)	
	65108	10/4 x 28" LOA (3 PHASE)	
7	10605	STRAIN RELIEF 3/4 NPT x .650-.750	2
8	10740	CONDUIT, LOCK NUT 3/4 NP	3
9	65087	STARTER MOUNT	1
10	10362	SCREW, MACHINE 8-32 x 3/4	4
11	10461	WASHER, INT. TOOTH #8	4
12	10462	NUT 8-32	4
13	10239	BELT AP-32	2
14		SHEAVE	1
	10555	2.5 OD x 2 Gr.A x 1-1/8 BORE (60 Hz MOTOR)	
	10526	3.00 OD x 2Gr.A x 1-1/8 BORE (50 Hz MOTOR)	
15	N/A	KEY 1/4" SQ. x 1-3/4 (INCL. w/ MOTOR)	1
16	65045	SHEAVE 4.05 OD x 2 Gr.A x SH	1
17	10505	BUSHING, SHEAVE SH x 1-1/4 BORE	1
18	40317	KEY 1/4 SQ. x 1-5/8	1
19	10984	CONN., LIQUID TITE 90D X 3/4NPT	1
20	77081	WASHER, FLAT 1-1/2 x 1-1/16 x .06	4
21		LOVATO STARTER w/ BLUE RESET BUTTON	1
		SPECIFY VOLTAGE FOR 50 Hz	
	16454	1 PHASE 230V 60 Hz, 11-M1-BRF-R30-26-23060	
	16457	3 PHASE 230V 60 Hz, 11-M1-BRF-R23-15-23060	
	16458	3 PHASE 460V 60 Hz, 11-M1-BRF-R14-10-46060	
22	10790	CONDUIT LOCK NUT 1/2 NP	2
23	40066	STRAIN RELIEF 1/2NPT X .350-.450"	1
24		WIRE HARNESS, STARTER TO POWER SOURCE	1
	65104	10/3 x 48" LOA (1 PHASE)	
	65105	10/4 x 48" LOA (3 PHASE)	
25	65106	WIRE HARNESS 16/4 x 36" LOA STARTER TO SWITCH	1
26	11565	CLAMP, LOOM 5/8 (SAE SIZE 10)	1
27	10831	WASHER, LOCK, INT. TOOTH #10	1
28	10877	SCREW, CAP STSHW 10-24 x 1/2	1
29	40037	PLUG, LOCKING 20A/250V L6-20P (1 PHASE ONLY)	1
30	40000	CONNECTOR, LOCKING 20A/250V L6-20R (1 PHASE ONLY)	1
31	16456	REMOTE SWITCH BOX COMPLETE	1
	16456-1	ENCLOSURE, LOVATO 2-BUTTON	1
	16456-2	ENCLOSURE BUTTON, GREEN FLUSH START	1
	16456-3	ENCLOSURE BUTTON, RED EXTENDED STOP	1
	16456-4	ENCLOSURE CONTACT, START GREEN N.O.	1
	16456-5	ENCLOSURE CONTACT, STOP RED N.C.	1
32	65088	REMOTE SWITCH BRACKET	1
33	11663	SCREW, MACHINE 8-32 X 1/2	4
34	10461	WASHER, INT. TOOTH #8	4
35	10462	NUT 8-32	4
36	10038	WASHER, LOCK 1/4	4
37	10846	SCREW, CAP STSHW 1/4-20 X 1/2	4
38	15204	PLUG, RECT. HOLE, PLASTIC SNAP-IN	1



A Division of Equipment Development Company, Inc.

100 Thomas Johnson Drive, Frederick, MD 21702-4600 USA

Phone (301) 663-1600 • 1-800-638-3326

Fax (301) 663-1607 • 1-800-447-3326

Website: www.edcoinc.com

Email: sales@edcoinc.com

Printed in USA

©2007

Page 9

ILLUSTRATION 5: CUTTER DRUM ASSEMBLY

STANDARD 8" WIDTH

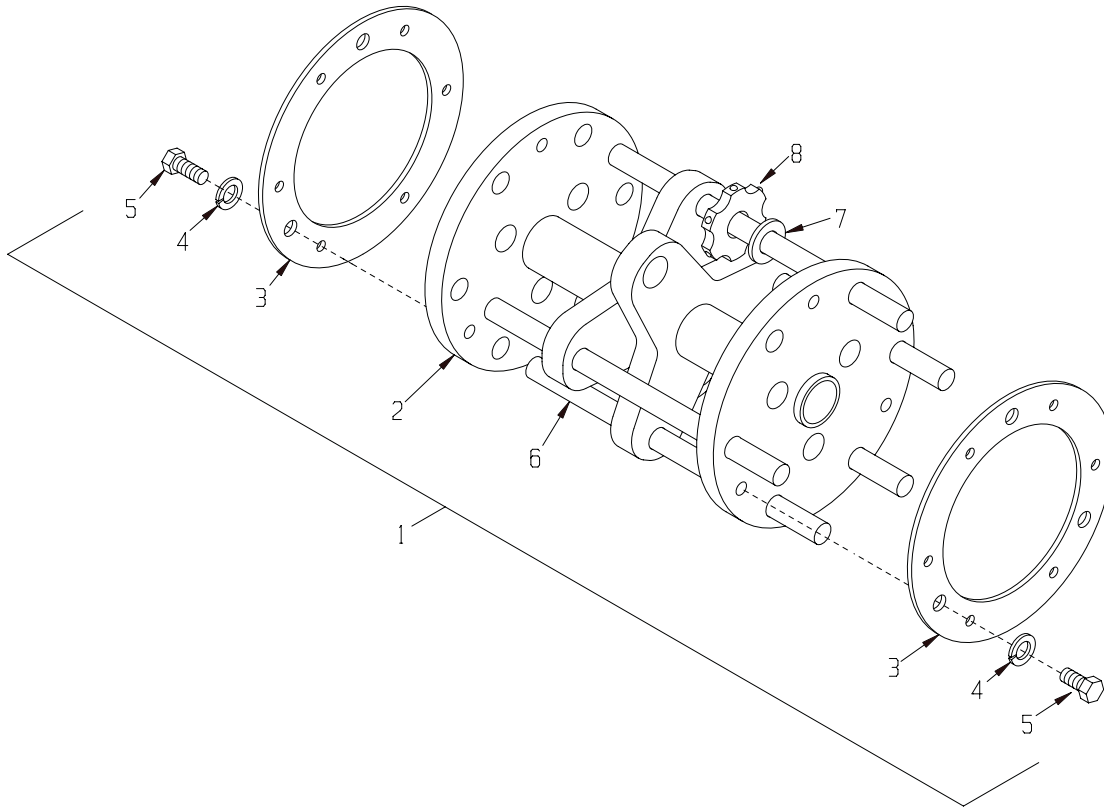

ITEM#	PART#	DESCRIPTION	QTY.
1	65050	DRUM ASSEMBLY, COMPLETE, CPM-8 CUTTER (INCLUDES ITEMS 2 THRU 6)	1
2	65051	DRUM ONLY , CUTTER	1
3	65054	RETAINING PLATE, CUTTER SHAFT	2
4	10801	WASHER, LOCK 5/16	6
5	10053	SCREW, CAP 5/16-18 x 3/4	6
6	20150	CP407 CUTTER SHAFT, 1/2 x 8-9/16"L	6
7	12230	CG227 SPACER, 1/2" ID	*
8	*	CUTTER WHEELS	*
	20156	CP206T, 6 POINT TUNGSTEN CARBIDE, (SHOWN) 1-3/4"OD x 5/8"ID x 1/4"THK	
	20336	CP207T 7 POINT SOLID CARBIDE CHUNKER, 1-1/2"OD x 1/2"ID x 1/2"THK	
	12206	JRS501P, 18 TOOTH POINTED HI CARBON STEEL, 2"OD x 1/2"ID x 3/16"THK	
	20206	CP305, 12 TOOTH FLAT TIP HI CARBON STEEL, 2"OD x 5/8"ID x 3/16"THK	

***NOTE:**
 CUTTER WHEELS AND SPACERS ARE NOT INCLUDED WITH DRUM ASSEMBLY.
 THE NUMBER OF CUTTER WHEELS AND SPACERS VARY WITH TYPE OF SET-UP USED.
 REFER TO ASSEMBLY INSTRUCTIONS FOR SUGGESTED SET-UPS AND QUANTITIES.

ILLUSTRATION 6: DIAMOND GROOVING HEAD ASSEMBLY

OPTIONAL 7" WIDTH

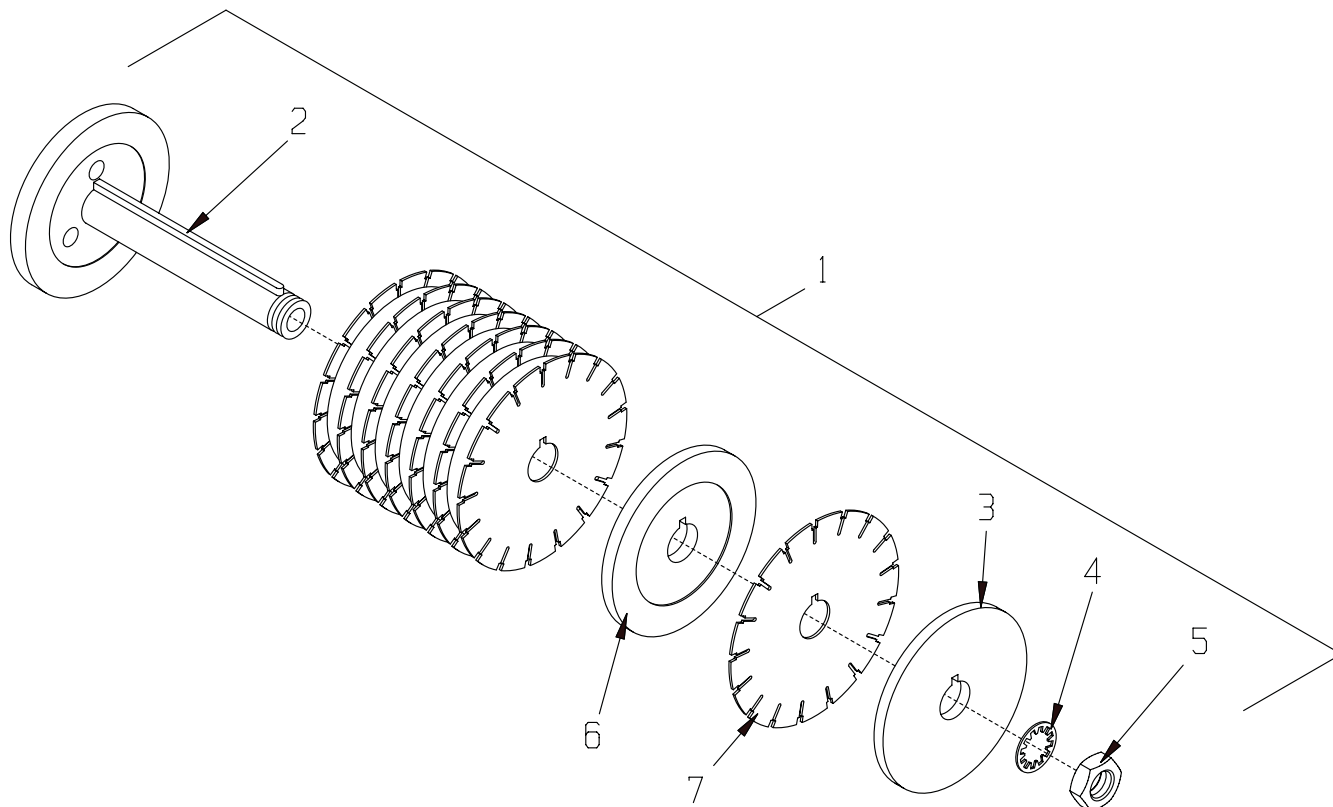

ITEM#	PART#	DESCRIPTION	QTY.
1	65077	DIAMOND GROOVING HEAD ASSEMBLY (INCLUDES ITEMS 2 THRU 5)	
2	65070	ARBOR, DIAMOND GROOVING HEAD	1
3	65071	ARBOR, BLADE RETAINING CAP 6"	1
4	65075	WASHER, LOCK, INT. TOOTH 1-1/4"	1
5	65076	NUT, JAM 1 1/4-12	1
6		SPACER, BLADE	*
	65072	6"O.D.x1-1/4" I.D.x.063" THK.	
	65073	6"O.D.x1-1/4" I.D.x.43" THK. (1/2" SPACING)	
	65074	6"O.D.x1-1/4" I.D.x.93" THK. (1" SPACING)	
	65078	6"O.D.x1-1/4" I.D.x5/8" THK.	
7	39808	DIAMOND BLADE 7x.090x1.25" w/ KEYWAY	*
	39806	DIAMOND BLADE 7X.250X1.25 w/ KEYWAY	
<p>*NOTE: DIAMOND BLADES AND SPACERS ARE NOT INCLUDED WITH HEAD ASSEMBLY. THESE QUANTITIES VARY WITH THE TYPE OF SET-UP USED. REFER TO SET-UP DRAWINGS FOR QUANTITIES.</p>			

ILLUSTRATION 7: OPTIONAL EDGER ASSEMBLY

PART NO. 65027

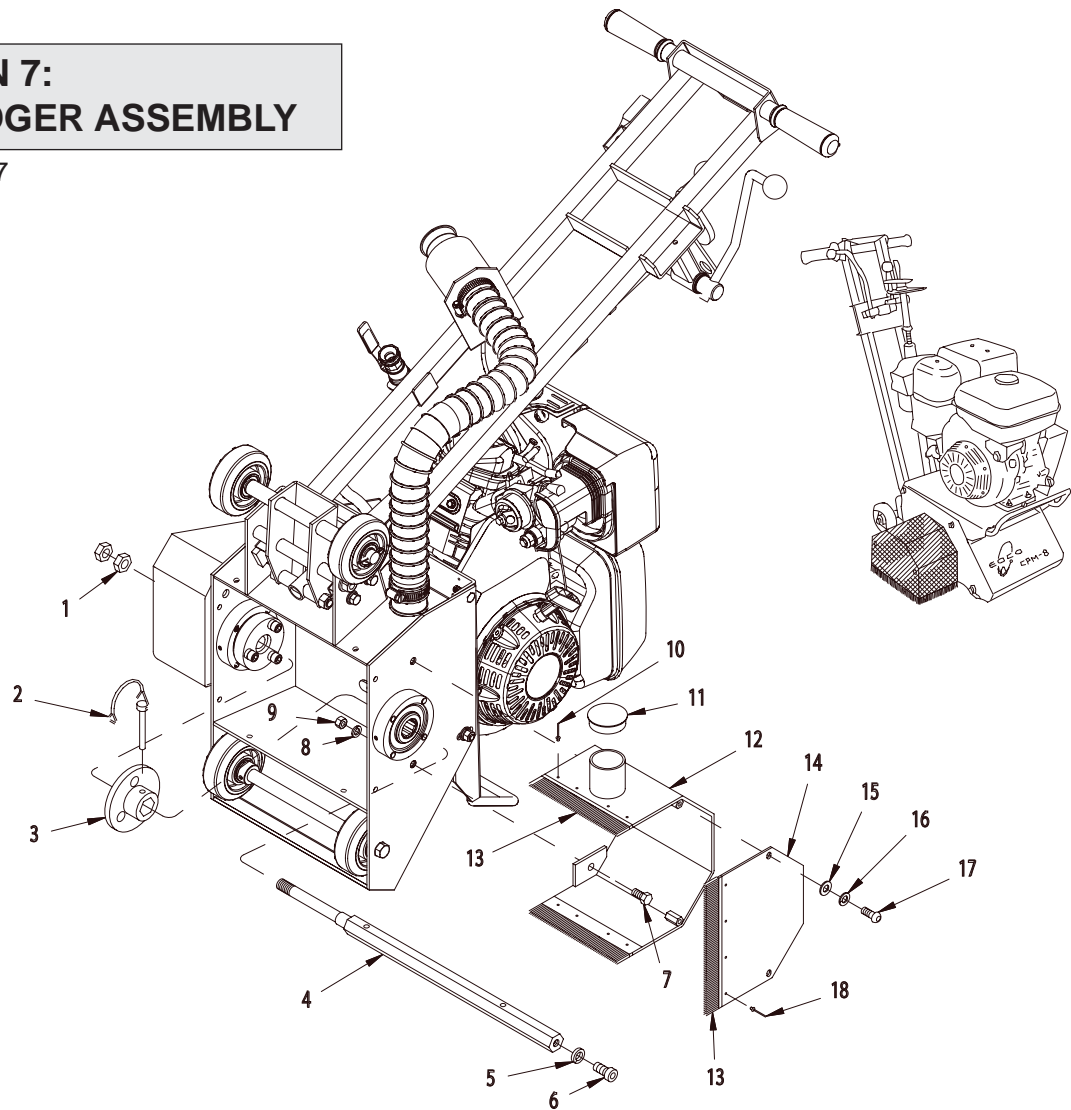

ITEM#	PART#	DESCRIPTION	QTY.
1	65039	NUT, JAM 5/8-11 LEFT-HAND THREAD	2
2	65028	PIN, WIRE LOCK 5/16x2-3/4	1
3	65026	FLANGE, DRIVER	1
4	65025	DRUM SHAFT, EDGER	1
5	10420	WASHER, LOCK 1/2 HEAVY-DUTY	1
6	10490	SCREW, SKT. HD. CAP 1/2-13x1	1
7	10055	SCREW, CAP 3/8-16 X 1	2
8	10811	WASHER, LOCK 3/8	2
9	10404	NUT 3/8-16	2
10	10134	RIVET, BLND 3/16X.450"L X.375HD DIA	8
11	65021	CAP/PLUG 2" RED PLASTIC, FLANGED	1
12	65023	COVER W/ BRUSHES	1
13	65029	BRUSHES, EDGER (SET OF 3, INCLUDED WITH ITEMS 12 & 14)	1
14	65024	COVER SIDE PANEL w/ BRUSH	1
15	10213	WASHER, FLAT 5/16	2
16	10801	WASHER, LOCK 5/16	2
17	10627	SCREW, SKT. BUTTON HEAD 5/16-18x3/4	2
18	10128	RIVET, BLIND 1/8 X .250L X .262HD	4

ILLUSTRATION 8: EDGER CUTTER DRUM ASSEMBLY

OPTIONAL 4" WIDTH

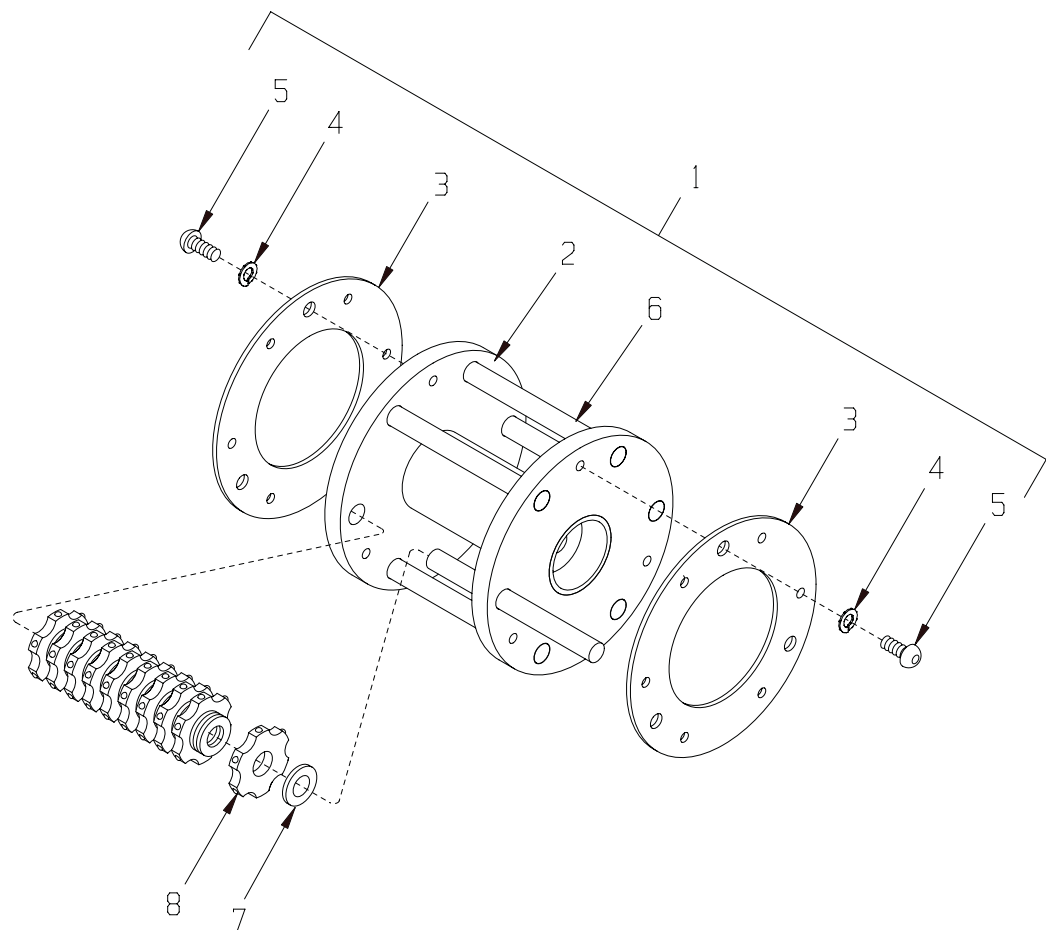

ITEM#	PART#	DESCRIPTION	QTY.
1	C66040	DRUM ASSEMBLY, COMPLETE, CPM-4 (INCLUDES ITEMS 2 THRU 6)	1
2	C66041	DRUM ONLY , CUTTER, CPM-4	1
3	65054	RETAINING PLATE, CUTTER SHAFT	2
4	10801	WASHER, LOCK 5/16	6
5	10627	SCREW, SKT. BUTTON HEAD 5/16-18 x 3/4	6
6	C66043	CP410 SHAFT, 1/2 X 5-3/16"L	6
7	12230	CG227 SPACER, 1/2" ID	*
8	*	CUTTER WHEELS	*
	20156	CP206T, 6 POINT TUNGSTEN CARBIDE, 1-3/4"OD x 5/8"ID x 1/4"THK	
	(SHOWN) 20336	CP207T 7 POINT SOLID CARBIDE CHUNKER, 1-1/2"OD x 1/2"ID x 1/2"THK	
	12206	JRS501P, 18 TOOTH POINTED HI CARBON STEEL, 2"OD x 1/2"ID x 3/16"THK	
	20206	CP305, 12 TOOTH FLAT TIP HI CARBON STEEL, 2"OD x 5/8"ID x 3/16"THK	

***NOTE:**
 CUTTER WHEELS AND SPACERS ARE NOT INCLUDED WITH DRUM ASSEMBLY.
 THE NUMBER OF CUTTER WHEELS AND SPACERS VARY WITH TYPE OF SET-UP USED.
 REFER TO ASSEMBLY INSTRUCTIONS FOR SUGGESTED SET-UPS AND QUANTITIES.

ILLUSTRATION 9: OPTIONAL SHAFT COVER KIT

PART NO. 65097K

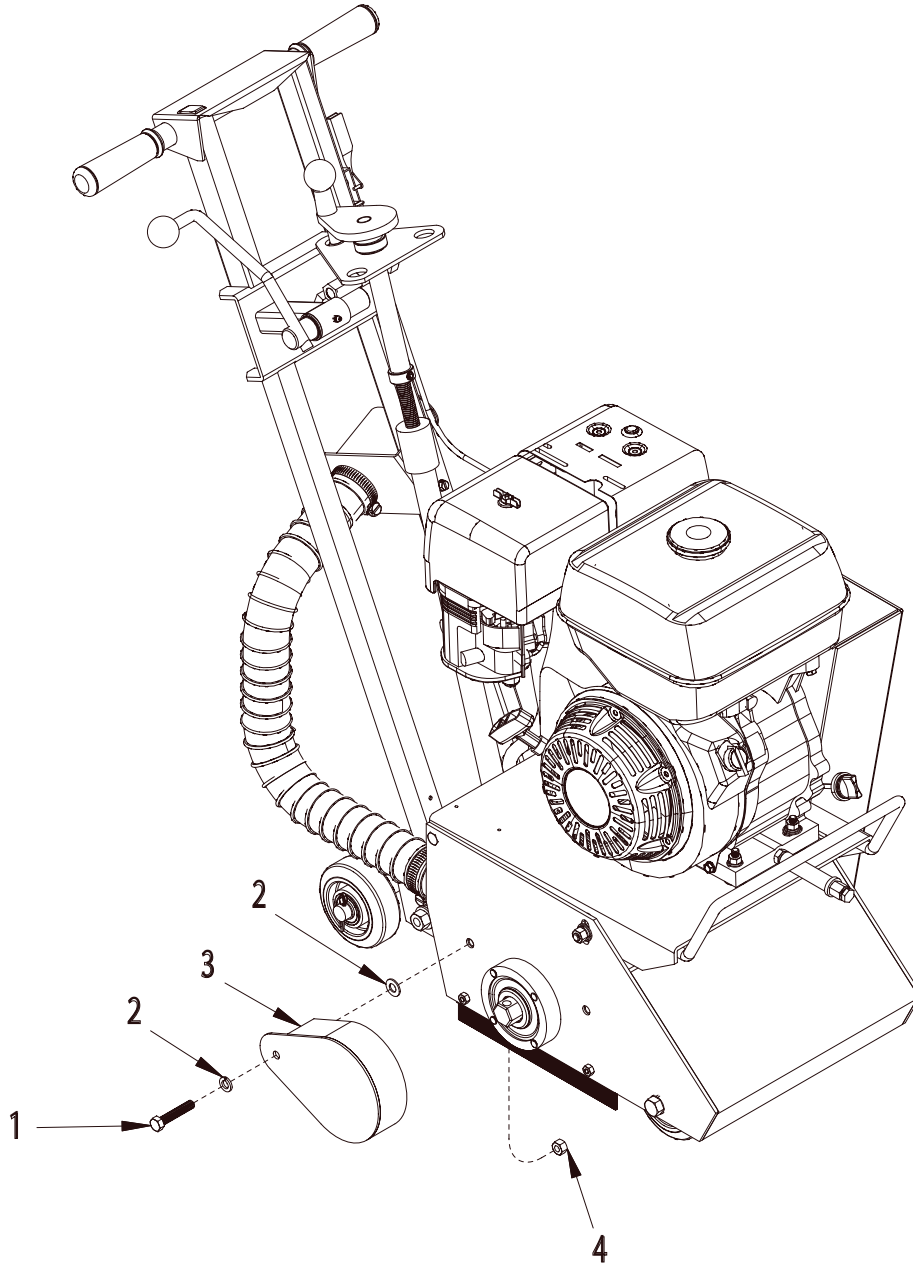

ITEM#	PART#	DESCRIPTION	QTY.
1	10410	BOLT, TAP 3/8-16 x 2-1/2 (FULL THD.)	1
2	10811	WASHER, LOCK 3/8	2
3	65097	COVER, SHAFT	1
4	10810	NUT, LOCK 3/8-16	1

WIRING DIAGRAM FOR ELECTRIC UNITS

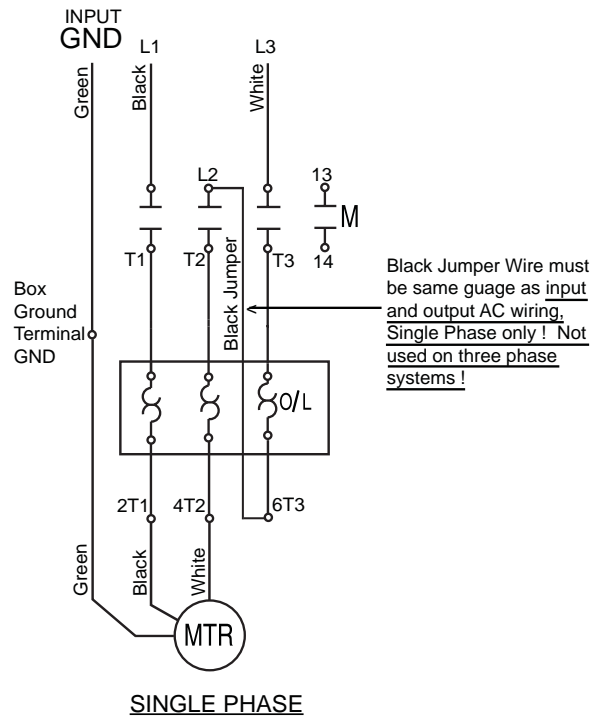
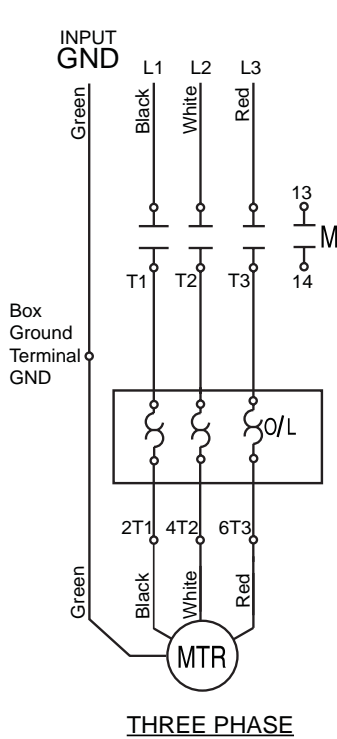
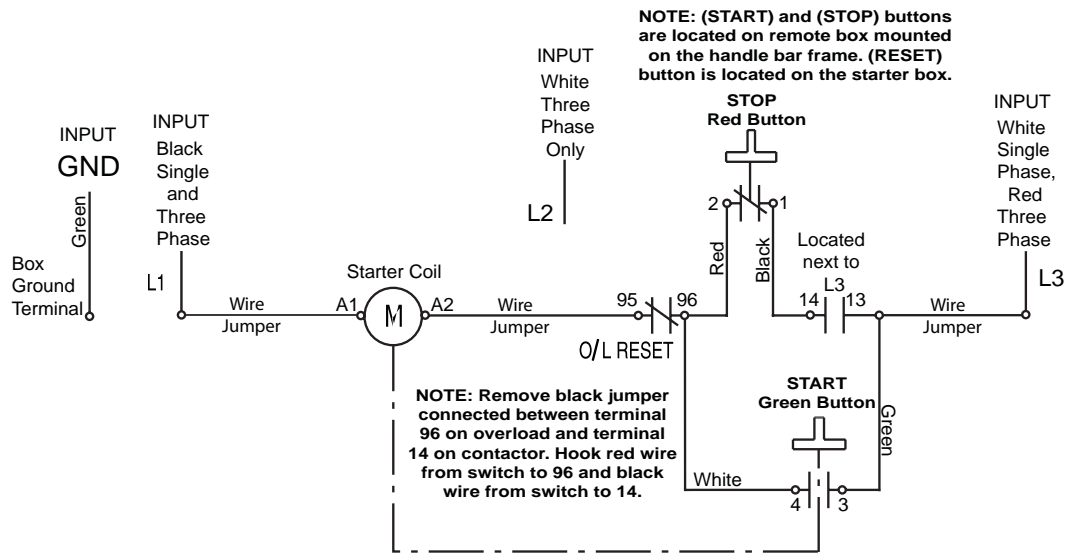

LIMITED EQUIPMENT WARRANTY OF SALE – TERMS & CONDITIONS

Equipment Development Company, Inc. herein referred to as EDCO (Seller) warrants that each new unit manufactured by EDCO to be free from defects in material and workmanship in normal use and service for a period of (1) one year (except for the cutter drum assembly on all model concrete/asphalt planes, in which case the warranty period shall be 90 days) from date of shipment to the original retail or equipment rental center owner.

Accessories or equipment furnished and installed on the product by EDCO but manufactured by others, including, but not limited to engines, motors, electrical components, transmissions etc., shall carry the accessory manufacturers own warranty.

EDCO will, at its option, repair or replace, at the EDCO factory or at a point designated by EDCO, any part which shall appear to the satisfaction of EDCO inspection to have been defective in material or workmanship.

EDCO reserves the right to modify, alter and improve any part or parts without incurring any obligation to replace any part or parts previously sold without such modified, altered or improved part or parts.

This warranty is in lieu of and excludes all other warranties, expressed, implied, statutory, or otherwise created under applicable law including, but not limited to the warranty of merchantability and the warranty of fitness for a particular purpose in no event shall seller or the manufacturer of the product be liable for special, incidental, or consequential damages, including loss of profits, whether or not caused by or resulting from the negligence of seller and/or the manufacturer of the product unless specifically provided herein. In addition, this warranty shall not apply to any products or portions thereof of which have been subjected to abuse, misuse, improper installation, maintenance, or operation, electrical failure or abnormal conditions and to products which have been tampered with, altered, modified, repaired, reworked by anyone not approved by seller or used in any manner inconsistent with the provisions of the above or any instructions or specifications provided with or for the product

FORCE MAJEURE

Seller's obligation hereunder are subject to, and Seller shall not be held responsible for, any delay or failure to make delivery of all or any part of the Product due to labor difficulties, fires, casualties, accidents, acts of the elements, acts of God, transportation difficulties, delays by a common carrier, inability to obtain Product, materials or components or qualified labor sufficient to timely perform part of or all of the obligations contained in these terms and conditions, governmental regulations or actions, strikes, damage to or destruction in whole or part of manufacturing plant, riots, terrorist attacks or incidents, civil commotions, warlike conditions, flood, tidal waves, typhoon, hurricane, earthquake, lightning, explosion or any other causes, contingencies or circumstances within or without the United States not subject to the Seller's control which prevent or hinder the manufacture or delivery of the Products or make the fulfillment of these terms and conditions impracticable. In the event of the occurrence of any of the foregoing, at the option of Seller, Seller shall be excused from the performance under these Terms and Conditions, or the performance of the Seller shall be correspondingly extended.

This document sets forth the terms and conditions pursuant to which the purchaser ("Purchaser") will purchase and Equipment Development Co.Inc. ("Seller") will sell the products, accessories, attachments (collectively the Products") ordered by the Purchaser. These terms and conditions shall govern and apply to the sale of Seller's Products to Purchaser, regardless of any terms and conditions appearing on any purchase order or other forms submitted by Purchaser to Seller, or the inconsistency of any terms therein and herein.

1. PRICE

All prices set forth on any purchase order or other document are F.O.B. Sellers facility or distribution point, as may be determined by Seller (F.O.B.Point). All prices are exclusive of any and all taxes, including, but not limited to, excise, sales, use, property or transportation taxes related to the sale or use of the Products, now or hereafter imposed, together with all penalties and expenses. Purchaser shall be responsible for collecting and/or paying any and all such taxes, whether or not they are stated in any invoice for the Products. Unless otherwise specified herein, all prices are exclusive of inland transportation, freight, insurance and other costs and expenses relating to the shipment of the Products from the F.O.B. point to Purchaser's facility. Any prepayment by Seller of freight insurance and other costs shall be for the account of Purchaser and shall be repaid to Seller.

2. PAYMENT TERMS

Payment terms are as follows. 2% 10 days (to approved and qualified accounts). Net 30 days. This is a cash discount for invoices paid within 10 days after the invoice date, regardless of date of receipt of shipment. This is not a trade discount and will not be granted to accounts that do not adhere to stated terms.

*All past due accounts are subject to a late payment fee of 1.5% per month or a maximum allowed by law if different, along with the expenses incidental to collection including reasonable attorney's fees and costs.

*Seller reserves the right to hold shipments against past due accounts.

*Seller reserves the right to alter payment terms.

3. FREIGHT TERMS

All shipments will be made F.O.B. shipping point as designated in these Terms and Conditions, and title shall pass at the F.O.B. point. Delivery to the initial common carrier shall constitute delivery to the Purchaser. Any claims for loss or damage during shipment are to be filed with carrier by the Purchaser. Seller will not assume responsibility for the performance of the carrier.

Back orders will be shipped in the most practical fashion with charges consistent with our freight policy established with the original order. UPS, FED EX, MAIL or shipments by other couriers are subject to the same terms and conditions as outlined in paragraph #3"Freight Terms".

4. DELIVERY, DAMAGES, SHORTAGES

Seller shall use reasonable efforts to attempt to cause the Products to be delivered as provided for in these Terms & Conditions. Delivery to the initial common carrier shall constitute the delivery to the Purchaser. Seller's responsibility, in so far as transportation risks are concerned ceases upon the delivery of the Products in good condition to such carrier at the F.O.B. point and all the Products shall be shipped at the Purchaser's risk. Seller shall not be responsible or liable for any loss of income and/or profits, or incidental, special, consequential damages resulting from Seller's delayed performance in shipment and delivery.

5. RETURN OF DEFECTIVE PRODUCTS

Defective or failed material shall be held at the Purchaser's premises until authorization has been granted by Seller to return or dispose of Products. Products that are to be returned for final inspection must be returned Freight Prepaid in the most economical way. Credit will be issued for material found to be defective upon Seller's inspection based on prices at time of purchase.

6. PRODUCTS ORDERED IN ERROR

Products may be returned, provided that claim is made and Seller is notified within 7 days of receipt of Products, and the Products are in original buyer's possession not more than 30 days prior to return, subject to Seller's approval. If Products are accepted for return, they must be Freight Prepaid and buyer will be charged a minimum of 15% rehandling charge, plus a charge back for outbound freight charges if the original order was shipped prepaid. Returns are not accepted for any Products that are specifically manufactured to meet the buyer's requirement of either specifications or quantity.

AGREEMENTS

These Terms and Conditions constitute the entire agreement between Seller and Purchaser as it relates to terms and conditions of sale, and supersedes any and all prior oral or written agreements, correspondence, quotations or understandings heretofore in force between the parties relating to the subject matter hereof. There are no agreements between Seller and Purchaser with respect to the Product herein except those specifically set forth in and made part of these terms and conditions. Any additional terms, conditions and/or prices are rejected by Seller.

These terms and conditions may be modified, cancelled or rescinded only by a written agreement of both parties executed by their duly authorized agents.

USE ONLY GENUINE EDCO PARTS & ACCESSORIES
For your own safety, the safety of others and the life of your machine.