

## Operator's Instruction Manual

# Model CD-3 & CD-5



CD-5



CD-3

## EDCO CHIP-DEK



100 Thomas Johnson Drive, Frederick, MD 21702-4600 USA  
Phone (301) 663-1600 • 1-800-638-3326  
Fax (301) 663-1607 • 1-800-447-3326  
Website: [www.edcoinc.com](http://www.edcoinc.com) • Email: [sales@edcoinc.com](mailto:sales@edcoinc.com)

Printed in USA  
TWW 2006

## READ AND UNDERSTAND THE OPERATOR'S INSTRUCTION MANUAL *THOROUGHLY* BEFORE ATTEMPTING TO OPERATE THIS EQUIPMENT.



Death or serious injury could occur if this equipment is used improperly.



### SAFETY MESSAGES

- Safety Instructions are preceded by a graphic alert symbol of DANGER, WARNING, or CAUTION.



Indicates an imminent hazard which, if not avoided, will result in death or serious injury.



Indicates an imminent hazard which, if not avoided, can result in death or serious injury.



Indicates hazards which, if not avoided, could result in serious injury and or damage to the equipment.

### AIR POWERED EQUIPMENT



- When operating this equipment, the operator must wear approved job related safety attire. Eye and hearing protection must be worn at all times while equipment is in use as sound levels exceed 92 dBA. Steel toe safety shoes should be worn. Head protection is required if work is performed overhead. Wear proper dust mask based on material being removed.
- Use the correct size air hose for the tool, 1/2" diameter (minimum). Hose and fittings must be rated for safe handling in excess of 100 PSI pressure. The working pressure of this tool is 80-90 PSI and should never be allowed to exceed 100 PSI.
- Limit the hose length to 30 feet (10 meters) maximum. Note: The pressure drop of 1/2" diameter hose is approximately 1 PSI per 90 linear feet.
- Limit the hose length to 30 feet (10 meters) maximum. Note: The pressure drop of 3/8" diameter hose is approximately 3 PSI per 90 linear feet.
- A filter/water separator must be provided on the air source to afford an adequate supply of clean, dry air to this machine.



• Disconnect the air supply before performing any maintenance on this machine. Use only genuine EDCO parts with this equipment. Failure to do so may result in serious bodily injury or death.

- Replace any damaged parts immediately. Use only genuine EDCO parts.

• Do **NOT** force the tool into the work. The hammering action of the tool will perform the work for you. If the tool does not seem to perform the work to your specifications, check the air supply to verify proper air pressure and lubricator is functioning properly. If if above suggestions do not remedy the problem call our customer service department at 1-800-638-3326 for possible solutions and trouble shooting.

### AIR POWERED EQUIPMENT CONTINUED

- To activate machine, attach the air source, firmly grip the machine and then turn the hand lever on the air valve on.

• After turning the air valve hand lever off, the tool will continue to operate for a few seconds. This is a normal result of stored up pressur in the machine casing being released gradually. **Be sure to firmly grip the machine until ALL air leaves the chamber.**

- Remove the air source from the machine when not in use.



• This equipment will create dust from the material being removed. That dust may contain a chemical known to the state of California to cause cancer and/or birth defects or other reproductive harm. Check the chemical properties of the materials to be removed.



• It is the operator's responsibility to keep other people (workers, pedestrians, bystanders, etc.) away during operation. Block off the work area in all directions with roping, safety netting, etc. for a safe distance. Failure to do so may result in others being injured by flying debris or exposing them to harmful dust and noise.

### DUST WARNING

Some dust created by power sanding, sawing, grinding, drilling, and other construction activities contains chemicals known to cause cancer, birth defects, or other reproductive harm. Some examples of these chemicals are:

- Lead from lead-based paints, and
- Crystalline silica from bricks and concrete and other masonry products.

Your risk of exposure to these chemicals varies depending on how often you do this type of work. To reduce your risk: work in a well ventilated area, use a dust control system, such as an industrial-style vacuum, and wear approved

### OPERATOR RESPONSIBILITIES

- Read and follow all safety decals and labels.
- Maintain a safe operating distance to other personnel.
- Be familiar with all aspects of the machine's operation and controls before applying power to the equipment.
- Use the correct accessory for the job being performed and material being removed. Make sure accessories are mounted correctly.
- Never operate this machine while under the influence of drugs or alcohol, while taking medications that impair the senses or reactions, or when excessively tired or under stress.
- Follow the instructions in the operator's manual and exercise caution.
- Comply with all local safety and health regulations as well as EPA and OSHA regulations.
- Maintain a copy of the equipment's operator's manual with the machine for reference at all times.

# Equipment Instruction Manual

## EDCO CD-3 & CD-5

### Table of Contents

<u>Section</u>	<u>Page Number</u>
Specifications	3
Safety Guidelines	4-5
Assemble the Wand, Hose Adapter	6
Starting the VAC-120	7
Maintenance Instructions	7
Inspect the Dust Bin (Bag), Connect the Hose	8
Cleaning/Changing Filters/Dust Bag	8-9
Cleaning the Motor Housing (Power Head)	10
	11
Maintenance Schedule	12
Limited Equipment Warranty	



**Figure 1**

#### HOW TO ORDER REPAIR PARTS

To ensure product safety and reliability, always use genuine EDCO replacement parts when making repairs to the equipment.

When ordering parts, please specify the MODEL and SERIAL NUMBER of the machine as given on the NAMEPLATE. In addition, give part number, description and quantity as listed on the parts list.

Please note: Due to improvements and changes in the equipment the illustrations shown may be different from the actual machine.

Toll Free: Voice 1-800-638-3326 • Fax 1-800-447-3326

#### CHIP DECK SPECIFICATIONS

Model	CD - 3	CD - 5
Width	21 1/2" / 54.6cm	29 1/2" / 74.9/ cm
Height	38 1/2" / 97.8cm	40 3/4" / 103.5cm
Length	39" / 99cm	44" / 111.7cm
Weight	165 lbs / 74.8 kg	275 lbs / 124.7 kg



100 Thomas Johnson Drive, Frederick, MD 21702-4600 USA

Phone (301) 663-1600 • 1-800-638-3326

Fax (301) 663-1607 • 1-800-447-3326

Website: [www.edcoinc.com](http://www.edcoinc.com) • Email: [sales@edcoinc.com](mailto:sales@edcoinc.com)

Printed in USA

TW 2006

**Page 3**



Read and understand the *Operator's Instruction Manual*,  
before operating this equipment.  
 Death or serious injury can result if this machine is used improperly.



## Safety Guidelines



Breathing  
Hazard



Eye  
Hazard



Hearing  
Hazard

As with all air powered equipment, care and attention must be exercised at all times during use, in addition to ensuring that routine and preventative maintenance is carried out periodically to ensure safe operation. Failure to carry out maintenance as necessary, including the replacement of parts to correct standards could render this equipment unsafe.



- Keep your machine clean.
- Keep hoses clear.
- Replace any worn or damaged parts with genuine EDCO parts immediately.
- Regularly examine hoses for damage, such as cracking or ageing. If damage is found, replace the hose before further use.



- Do not use steam cleaners or pressure washers to clean the machine.
- Do not immerse in water for cleaning.
- Do not attempt machine maintenance or cleaning unless the air supply has been removed from the machine.
- Do not allow any modifications that do not meet the quality and standards of the original equipment.
- Do not run the machine over the air supply hose during operation as a hazard may occur.
- Do not try to pull on the hose to disconnect the machine from the air supply.

Safety warnings and guidelines do not by themselves eliminate danger.  
 They are not substitutes for proper accident prevention and good judgement.

## TUNGSTEN CARBIDE BITS

Use 5-Point bits for general purpose removal of concrete due to spalling, blistering, excess surface material, or in preparation of bonding new concrete overlays. Depth of removal is generally 1/4" or more and is dependent on the speed with which the unit is moved across the surface.



### 5 - POINT

Item no. 18810

General surface removal  
Penetration up to 1/4 inch.

The 9-Point bits achieve surface removal of approximately 1/8". Creating an excellent bonding texture for overlays of thin coats of polymer concrete, epoxy or urethane. Also ideal for producing slip-resistant surfaces for fork trucks and other vehicular traffic.



### 9 - POINT

Item no. 18820

Laitance removal  
Fine scabbling  
Anti-slip surfacing  
Penetration to 1/8 inch.

\*\*\*WARNING\*\*\*

"DO IT RIGHT" OR RISK SEVERE PERSONAL INJURY.  
FOLLOW INSTRUCTIONS CAREFULLY

\*\*\*WARNING\*\*\*

Bits are easily and quickly changed or replaced. The uses listed above are merely suggested. Your own trials will determine which bit fits your need best. Choose the correct type to do the job. Use a hammer and punch to drive out the bit retaining pins. Remove the bits, replace and drive the retaining pins back in securely. If pins are loose or worn replace with new tight fitting pins.



100 Thomas Johnson Drive, Frederick, MD 21702-4600 USA  
Phone (301) 663-1600 • 1-800-638-3326  
Fax (301) 663-1607 • 1-800-447-3326  
Website: [www.edcoinc.com](http://www.edcoinc.com) • Email: [sales@edcoinc.com](mailto:sales@edcoinc.com)

Printed in USA

TW 2006

Page 5

# Guide to Operation

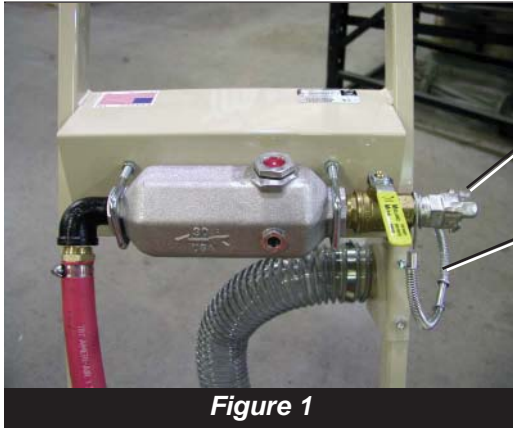

Figure 1

Connect air supply hose to connector on machine.

Connect "WHIPCHECK" on machine to air supply hose.

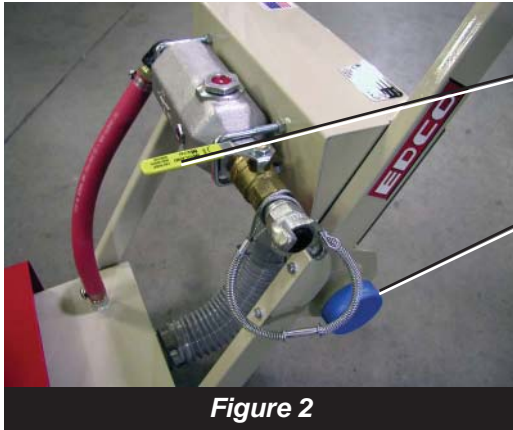

Figure 2

Position yourself behind machine and turn operating lever to operating position and proceed to operate machine.

Connect industrial vacuum to vacuum port on machine.

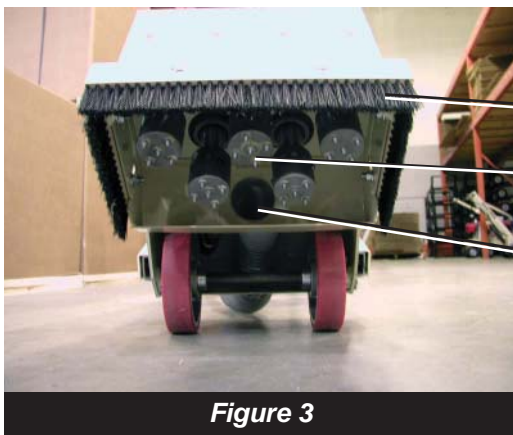

Figure 3

View of underside of machine.

Dust skirt

Bits

Vacuum port

# INSTRUCTIONS FOR EDCO MODEL CD-5 & CD-3 “CHIP-DEK” SCABBLER

## **BEFORE STARTING OPERATION:**

For efficient operation of the CD-5 & CD-3, be sure to use a compressor with adequate output. A compressor output of 150 CFM @ 90 PSI or larger is recommended.

Also, check the level of the lubricator. The proper oil to use is one with a viscosity of 32 centi-strokes (ISO-32). For example, Citgo AW-32 hydraulic oil or Lubriplate HO-32 hydraulic oil.

Tilt machine backwards and check the condition and secureness of the five or three carbide bits.

Use an industrial vacuum to control dust with sufficient CFM, hook-up the EDCO VAC-500 or VAC250 Industrial dust control vacuum system, or equivalent, to the three inch vacuum port on a CD-5 and a VAC-250 or VAC-160 or equivalent on a CD-3.

**WARNING** Determine if the slab is structurally sound and safe. While the CD-5 & CD-3 delivers a controlled impact and should not damage the base, care should be taken that the slab is strong enough to withstand the impact of repeated hammering. **A slab less than 4 inches thick may crack under repeated hammering.**

## **OPERATING MACHINE:**

Before starting, this machine be sure to read and understand this entire operator's manual. Hook air hose (3/4" minimum) from a regulated and filtered air supply to the coupler on the handle of the CD-5 or CD-3 and do not exceed 60 feet of 3/4" hose.

**WARNING** Be sure to use a “whipchek” safety cable at this joint. Failure to do so could result in serious bodily injury or death. Before supplying the air hose with air, ensure that the operating valve on the console of the CD-5 or CD-3 is in the “OFF” position.

To start operation of the CD-5 or CD-3, grasp handle bars and turn operating valve to the “ON” position and pistons will start pounding the pavement. The CD-5 or CD-3 will feel as though the front head is floating. It will be necessary to move the machine so that it will not pound pockets into the slab. The CD-5 or the CD-3 should be moved slowly in a side to side sweeping motion to ensure a consistently uniform removal of material. As the machine is operating, it may become necessary to adjust the hammering action of the CD-5 or CD-3. The addition of an air pressure regulator between the machine and your compressor will allow for this adjustment. The air pressure flowing to the pistons in the cylinder head may be adjusted from 0 PSI, minimum, to 90 PSI, maximum.



The air pressure should be regulated between 40 PSI and the maximum of 90 PSI depending on how aggressive the machine needs to be to accomplish the job. During the operation of the CD-5 or CD-3, it will be necessary to periodically stop the machine and visually inspect the level of condensation (water) that might accumulate in the water filter bowl located near your air supply (compressor). If the accumulation of water exceeds the maximum level as marked on the water filter bowl, it will be necessary to drain the water filter bowl near your air supply. Check owners manual of your compressor on how to drain the water filter bowl.

In addition, during the operation of the CD-5 or CD-3 it will be necessary to maintain the correct amount of oil in the lubricator. This oil in the lubricator is essential to the operating life of the components in the cylinder head. The proper oil in the airflow reaching the pistons and cylinders will help flush away any contaminants as well as lubricate the close tolerance components and will leave a non-corrosive film to eliminate rusting of the surfaces. The adjustment is located under the cap with the red center as shown *Figure 4*, below follow manufacturers instructions for adjustment.

Turning the adjustment screw counter-clockwise will increase the oil drip rate and turning adjustment screw clockwise will decrease the oil drip rate. The drip rate is set at the factory all the way counter-clockwise to the maximum (+) position. Each piston should be receiving lubrication and have a light film of oil on the surface, just enough to “see” it. If oil starts to appear on the surface, then decrease the oil drip rate. Excess oil will stain the concrete, insufficient oil will result in damage to the equipment.

When work is complete, close the air compressor outlet valve then turn CD-3 or CD-5 operating valve to the “ON” position to empty the high pressure air from the hose before disconnecting the machine from the compressor. **Be sure to disconnect the CD-3 or CD-5 from the air source when not in use.**

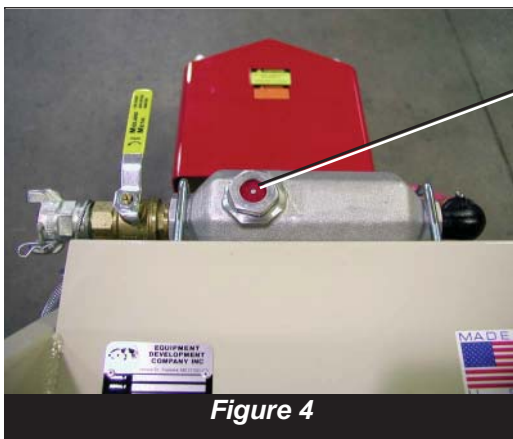

*Figure 4*

Check oil level at this point and add if needed.

## Maintenance Schedule



Repairs are to be preformed by EDCO or by approved EDCO repair technicians.

	Before Operation			As Necessary
Inspect Entire Machine	X			
Check Lubricator	X			
Inspect Hoses	X			
Inspect/Tighten Hardware				X



Read and follow all instructions in the Operator's Instruction Manual.

### Maintenance:

If the CD-3 or CD-5 is to be stored or not used for **extended** periods of time it is recommended that the following suggestions be followed:

- (1) Drain moisture from water filter (at compressor).
- (2) Fill lubricator with proper grade of oil (*Figure 4*).

Refer to page 10 (*Figures 5 & 6*) to complete the following.

- (3) Remove top plate from cylinder block, remove top caps, and generously apply the proper oil to top of pistons. Manually move the pistons up and down through their cycle several times to ensure all surfaces are coated with oil. Generously oil the top of the cylinders. Reassemble the machine taking care to ensure that the o-ring seals on the cylinder top caps are not damaged.

### TROUBLE SHOOTING GUIDE

FAULT	POSSIBLE	REMEDIES
<b><u>Machine will not operate.</u></b>	Cylinders or valves clogged with dirt. Insufficient air supply. Valve not turned on. Low oil level.	Strip and clean. Check compressor output. Turn on valve. Add proper amount and grade of oil.
<b><u>Finish of work is unsatisfactory.</u></b>	Incorrect or worn bits.	Replace with new or correct bits.
<b><u>Dust level is unacceptable.</u></b>	Operating environment.	Moisten area to be machined with water or utilize an industrial vacuum system.
<b><u>Work rate is too low.</u></b>	Insufficient air supply. Worn bits.	Check compressor output. Check hose size. Check clearance between piston, cylinder and liner - (.006" Max.)



100 Thomas Johnson Drive, Frederick, MD 21702-4600 USA  
 Phone (301) 663-1600 • 1-800-638-3326  
 Fax (301) 663-1607 • 1-800-447-3326  
 Website: www.edcoinc.com • Email: sales@edcoinc.com

Printed in USA

TW 2006

Page 9

(Figure 5) on right is piston detail for reference.

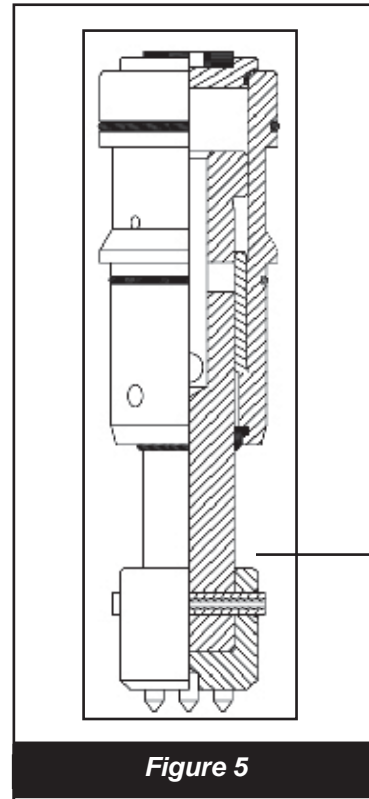

(Figure 6) below is detail of cylinder block and parts description for maintenance purposes only.

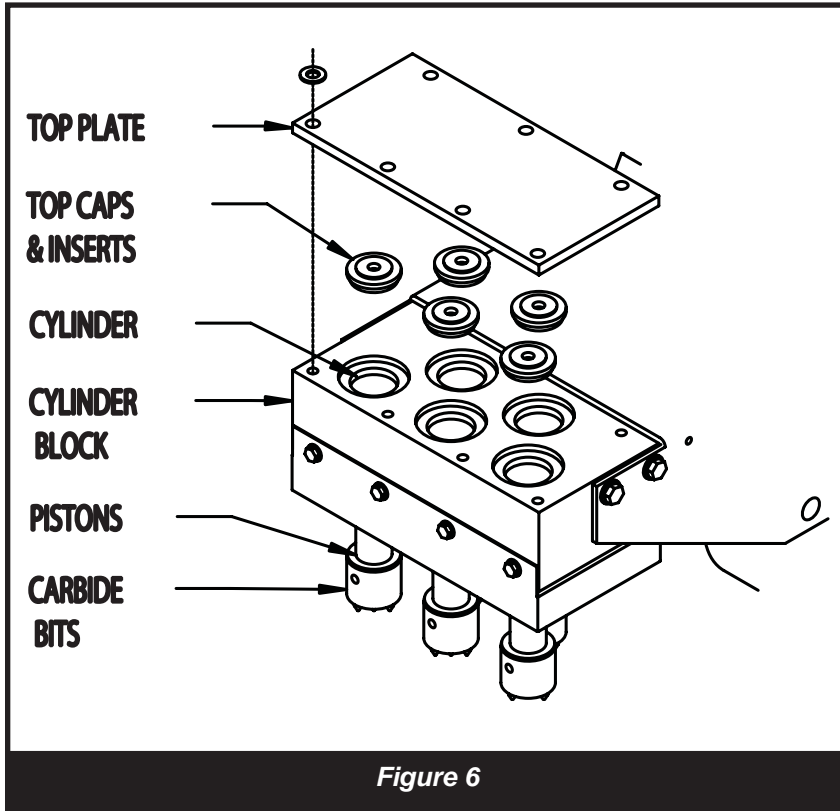

Optional Slide Hammer for removing CD-3 and CD-5 bits.

# INSTALLATION INSTRUCTIONS FOR NEW STYLE CHIP-DEK BITS

NOTE: NEW STYLE BITS WILL FIT ALL EDCO CHIP-DEK UNITS.

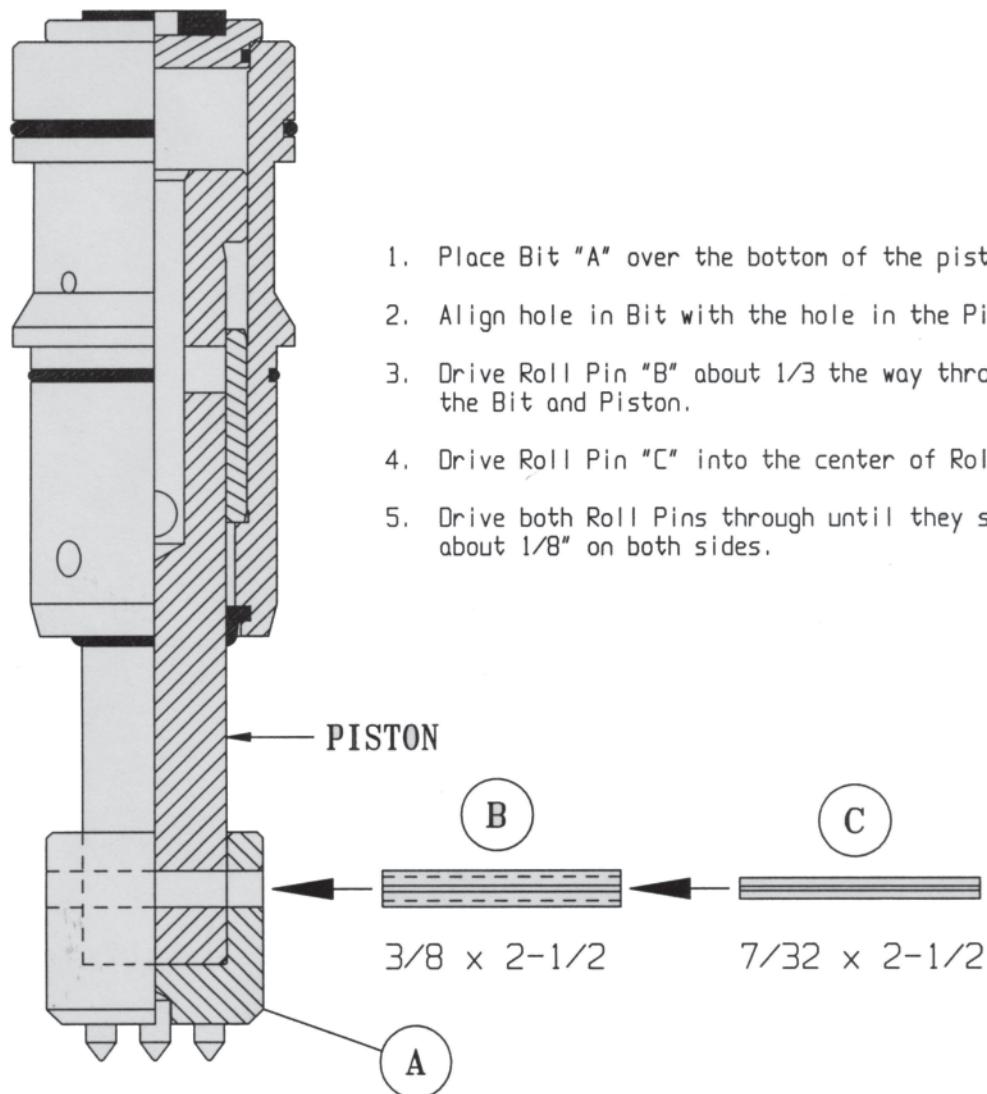

**LIMITED EQUIPMENT WARRANTY OF SALE – TERMS & CONDITIONS**

Equipment Development Company, Inc. herein referred to as EDCO (Seller) warrants that each new unit manufactured by EDCO to be free from defects in material and workmanship in normal use and service for a period of (1) one year (except for the cutter drum assembly on all model concrete/asphalt planes, in which case the warranty period shall be 90 days) from date of shipment to the original retail or equipment rental center owner.

Accessories or equipment furnished and installed on the product by EDCO but manufactured by others, including, but not limited to engines, motors, electrical components, transmissions etc., shall carry the accessory manufacturers own warranty.

EDCO will, at its option, repair or replace, at the EDCO factory or at a point designated by EDCO, any part which shall appear to the satisfaction of EDCO inspection to have been defective in material or workmanship.

EDCO reserves the right to modify, alter and improve any part or parts without incurring any obligation to replace any part or parts previously sold without such modified, altered or improved part or parts.

This warranty is in lieu of and excludes all other warranties, expressed, implied, statutory, or otherwise created under applicable law including, but not limited to the warranty of merchantability and the warranty of fitness for a particular purpose in no event shall seller or the manufacturer of the product be liable for special, incidental, or consequential damages, including loss of profits, whether or not caused by or resulting from the negligence of seller and/or the manufacturer of the product unless specifically provided herein. In addition, this warranty shall not apply to any products or portions thereof which have been subjected to abuse, misuse, improper installation, maintenance, or operation, electrical failure or abnormal conditions and to products which have been tampered with, altered, modified, repaired, reworked by anyone not approved by seller or used in any manner inconsistent with the provisions of the above or any instructions or specifications provided with or for the product

**FORCE MAJEURE**

Seller's obligation hereunder are subject to, and Seller shall not be held responsible for, any delay or failure to make delivery of all or any part of the Product due to labor difficulties, fires, casualties, accidents, acts of the elements, acts of God, transportation difficulties, delays by a common carrier, inability to obtain Product, materials or components or qualified labor sufficient to timely perform part of or all of the obligations contained in these terms and conditions, governmental regulations or actions, strikes, damage to or destruction in whole or part of manufacturing plant, riots, terrorist attacks or incidents, civil commotions, warlike conditions, flood, tidal waves, typhoon, hurricane, earthquake, lightning, explosion or any other causes, contingencies or circumstances within or without the United States not subject to the Seller's control which prevent or hinder the manufacture or delivery of the Products or make the fulfillment of these terms and conditions impracticable. In the event of the occurrence of any of the foregoing, at the option of Seller, Seller shall be excused from the performance under these Terms and Conditions, or the performance of the Seller shall be correspondingly extended.

This document sets forth the terms and conditions pursuant to which the purchaser ("Purchaser") will purchase and Equipment Development Co. Inc. ("Seller") will sell the products, accessories, attachments (collectively the Products) ordered by the Purchaser. These terms and conditions shall govern and apply to the sale of Seller's Products to Purchaser, regardless of any terms and conditions appearing on any purchase order or other forms submitted by Purchaser to Seller, or the inconsistency of any terms therein and herein.

**1. PRICE**

All prices set forth on any purchase order or other document are F.O.B. Sellers facility or distribution point, as may be determined by Seller (F.O.B. Point). All prices are exclusive of any and all taxes, including, but not limited to, excise, sales, use, property or transportation taxes related to the sale or use of the Products, now or hereafter imposed, together with all penalties and expenses. Purchaser shall be responsible for collecting and/or paying any and all such taxes, whether or not they are stated in any invoice for the Products. Unless otherwise specified herein, all prices are exclusive of inland transportation, freight, insurance and other costs and expenses relating to the shipment of the Products from the F.O.B. point to Purchaser's facility. Any prepayment by Seller of freight insurance and other costs shall be for the account of Purchaser and shall be repaid to Seller.

**2. PAYMENT TERMS**

Payment terms are as follows. 2% 10 days (to approved and qualified accounts). Net 30 days. This is a cash discount for invoices paid within 10 days after the invoice date, regardless of date of receipt of shipment. This is not a trade discount and will not be granted to accounts that do not adhere to stated terms.

\*All past due accounts are subject to a late payment fee of 1.5% per month or a maximum allowed by law if different, along with the expenses incidental to collection including reasonable attorney's fees and costs.

\*Seller reserves the right to hold shipments against past due accounts.

\*Seller reserves the right to alter payment terms.

**3. FREIGHT TERMS**

All shipments will be made F.O.B. shipping point as designated in these Terms and Conditions, and title shall pass at the F.O.B. point. Delivery to the initial common carrier shall constitute delivery to the Purchaser. Any claims for loss or damage during shipment are to be filed with carrier by the Purchaser. Seller will not assume responsibility for the performance of the carrier.

Back orders will be shipped in the most practical fashion with charges consistent with our freight policy established with the original order. UPS, FED EX, MAIL or shipments by other couriers are subject to the same terms and conditions as outlined in paragraph #3 "Freight Terms".

**4. DELIVERY, DAMAGES, SHORTAGES**

Seller shall use reasonable efforts to attempt to cause the Products to be delivered as provided for in these Terms & Conditions. Delivery to the initial common carrier shall constitute the delivery to the Purchaser. Seller's responsibility, in so far as transportation risks are concerned ceases upon the delivery of the Products in good condition to such carrier at the F.O.B. point and all the Products shall be shipped at the Purchaser's risk. Seller shall not be responsible or liable for any loss of income and/or profits, or incidental, special, consequential damages resulting from Seller's delayed performance in shipment and delivery.

**5. RETURN OF DEFECTIVE PRODUCTS**

Defective or failed material shall be held at the Purchaser's premises until authorization has been granted by Seller to return or dispose of Products. Products that are to be returned for final inspection must be returned Freight Prepaid in the most economical way. Credit will be issued for material found to be defective upon Seller's inspection based on prices at time of purchase.

**6. PRODUCTS ORDERED IN ERROR**

Products may be returned, provided that claim is made and Seller is notified within 7 days of receipt of Products, and the Products are in original buyer's possession not more than 30 days prior to return, subject to Seller's approval. If Products are accepted for return, they must be Freight Prepaid and buyer will be charged a minimum of 15% rehandling charge, plus a charge back for outbound freight charges if the original order was shipped prepaid. Returns are not accepted for any Products that are specifically manufactured to meet the buyer's requirement of either specifications or quantity.

**AGREEMENTS**

These Terms and Conditions constitute the entire agreement between Seller and Purchaser as it relates to terms and conditions of sale, and supersedes any and all prior oral or written agreements, correspondence, quotations or understandings heretofore in force between the parties relating to the subject matter hereof. There are no agreements between Seller and Purchaser with respect to the Product herein except those specifically set forth in and made part of these terms and conditions. Any additional terms, conditions and/or prices are rejected by Seller.

These terms and conditions may be modified, cancelled or rescinded only by a written agreement of both parties executed by their duly authorized agents.

**USE ONLY GENUINE EDCO PARTS & ACCESSORIES**  
**For your own safety, the safety of others and the life of your machine.**

**Equipment Development Company, Inc.**

